



EASY CLEAN™ 1000

THE ULTIMATE IN SANITARY CONVEYOR DESIGN

PrH

PRODUCT
HANDLING

> Ideal for heavy washdown applications

Shuttleworth® has developed the next generation of stainless steel conveyors with its Easy Clean™ Sanitary Conveyor Series, designed to meet the specific needs of the food and pharmaceutical industries. Shuttleworth's Easy Clean conveyors provide advanced cleanability, peak performance, reliability and easy maintenance.

The Easy Clean 1000 offers the pinnacle in sanitation and cleanability. Its ultra-sanitary design includes #4 polished stainless steel, corrosion resistant construction with continuous welds and inventive 45-degree stainless steel bends for added strength and durability. The angled bends allow debris to fall through the conveyor surface and frame structure - rather than collect on the horizontal surface. Sanitary grade bearings are used throughout to withstand the high pressure, corrosive washdown procedures to ensure safety. Shuttleworth's Easy Clean 1000 is also equipped with its patented Slip-Torque® roller technology to accommodate a variety of food grade and pharmaceutical applications.

FEATURES AND BENEFITS

- **Easy Clean 1000 Frame Design** - Minimizes horizontal surfaces where food or other contaminants can collect
- **Durable Stainless Steel Construction** - Built to Industry and Specific Government Compliance Standards
- **Corrosion Resistant Components** - Ideal for heavy washdown applications
- Offer both standard and custom application design capabilities
- Suitable for food, bakery, pharmaceutical, medical and other hygienic environments

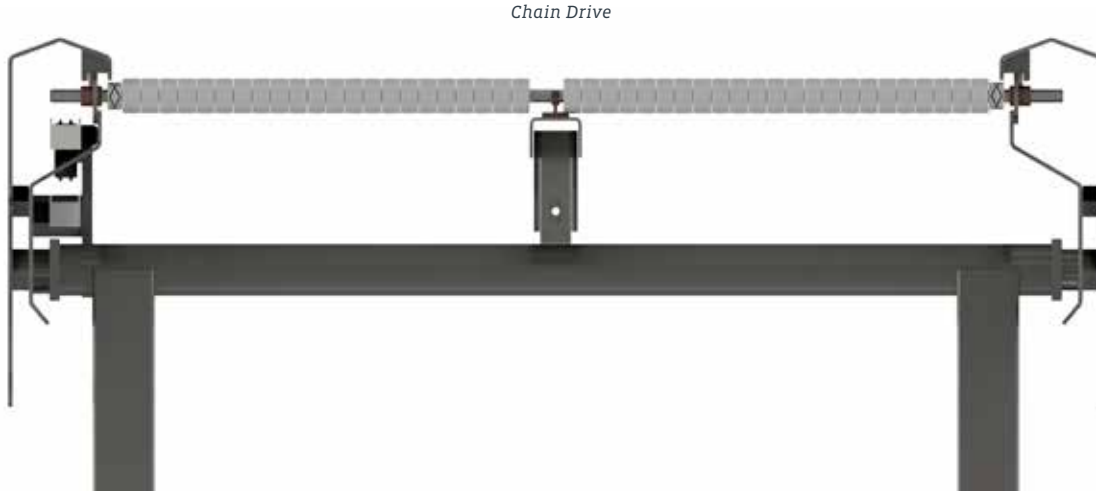

Available in standard ½ meter lengths, the Easy Clean 1000 can accommodate up to 22 standard widths – and, Shuttleworth can customize its conveyors to meet the customer’s specific product application needs. Shuttleworth’s conveyor systems are engineered for product applications requiring low back pressure accumulation for gentle product handling to ensure product integrity in manufacturing and packaging lines. Specialty devices offering combining, dividing, indexing, positioning, stacking and more are also available to complement Easy Clean 1000 conveyors.

Line after line, decade after decade, more manufacturers trust Shuttleworth for their product handling needs.

THE SHUTTLEWORTH ADVANTAGE

Improving your product quality doesn’t have to be difficult. With our accumulation and buffering capabilities, we can help simplify your product handling and packaging processes to maximize your product output, protect product integrity, and improve your overall manufacturing efficiencies.

From automotive and electronics, to paper conversion and pharmaceuticals, to food and consumer good markets and beyond, manufacturers across the globe rely on Shuttleworth’s proven product handling solutions to increase line efficiency, maximize profitability, and minimize risk. As part of the ProMach Product Handling business line, Shuttleworth helps our packaging customers protect and grow the reputation and trust of their consumers. ProMach is performance, and the proof is in every package.